

PULLTECH[®]

GT60

**20.000 KGF
(44,000 LBF)**

GT60

20.000 KGF (44,000 LBF)

PULLTECH®

TALHAS INDUSTRIAIS INDUSTRIAL HOISTS

EQUIPAMENTOS STANDARD STANDARD EQUIPMENT

- Redutor planetário de alto desempenho e durabilidade.
- Freio multidisco de arraste em banho de óleo, atua somente no sentido de descer carga.
- Comando por botoeira pendente (cabo de 6 metros).
- Cabo de aço galvanizado com gancho e trava de segurança.
- Tambor montado sobre rolamentos de esferas com lubrificação permanente.
- Leve, compacto e portátil.
- Excelente para uso geral em içamento, para aplicação em pórticos ou guindastes giratórios em uso industrial. Modelos monofásicos operam ligados a tomadas domésticas.
- Peso bruto (sem cabo de aço): 357 Kgf.
- High-performance and durable planetary gearbox.
- Oil-bath multi-disc drag brake, acting only in the load lowering direction.
- Pendant control (19,7 feet cable).
- Galvanized wire rope with hook and safety latch.
- Drum mounted on ball bearings with permanent lubrication.
- Lightweight, compact and portable.
- Excellent for general hoisting applications, suitable for gantries or jib cranes in industrial use. Single-phase models operate connected to standard household outlets.
- Gross Weight (without wire rope): 787 LB

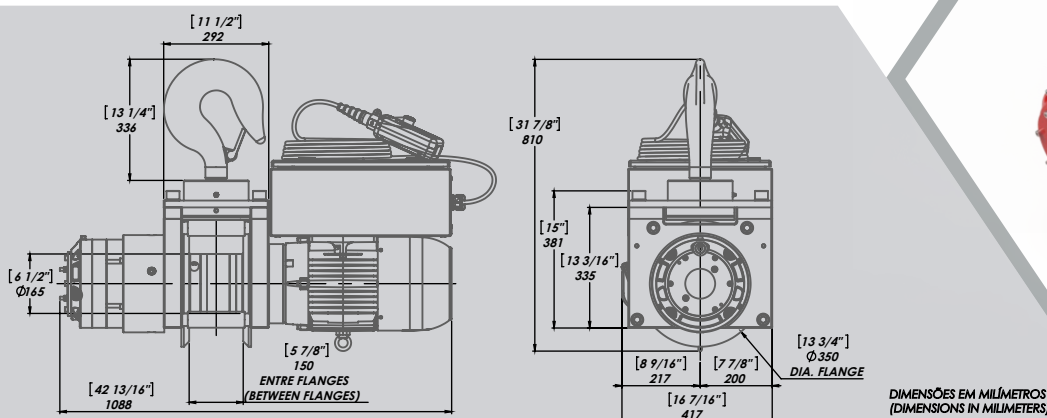

Copyright 2026 - PULLTECH
All Rights Reserved

PULLTECH

PULLTECH - Engenharia e Indústria de Equipamentos Hidráulicos e Mecânicos LTDA
Rua João Pinto de Faria, S/N - Loteamento São João
Nova Friburgo / RJ - Brasil
CEP: 28605-260
Telefone (Phone): (22) 2522-0155 / E-mail: comercial@pulltech-eng.com
Celular (Mobile): (22) 9.8812-4850
www.pulltech-eng.com



CAT-GT60
REV 2
MAR 2026

GT60
20.000 KGF (44,000 LBF)

PULLTECH

DESEMPENHO POR CAMADA
PERFORMANCE BY LAYER

GT60-D-200T-CR1

Motor Eléctrico 7,5CV (Electric Motor 5,5kW)

440 Vac – 60 Hz

Diâm. Cabo (Wire Rope Diameter): 22 mm (7,8")

	TRAÇÃO <i>LINE PULL</i>		VEL. LINHA <i>LINE SPEED</i>	
	KGF	LBF	M/MIN.	FT/MIN.
1	20.999	46,295	1,4	4.6
2	16.999	37,476	1,7	5.6
3	14.279	31,480	2,0	6.6

ARMAZENAMENTO
STORAGE CAPACITY:

CABO (ROPE) Ø: 22 mm

TAMBORES <i>DRUMS</i>	D
CAMADAS <i>LAYERS</i>	3
QUANTIDADE <i>LENGTH</i>	12m (39ft)

CÓDIGO (CODE EXPLANATION):

GT 60 - D - 200T - CR1

GT	TALHAS INDUSTRIAIS (INDUSTRIAL HOISTS)
60	SÉRIE (SERIE)
D	MODELO TAMBOR (DRUM MODEL)
200T	CAPACIDADE (CAPACITY)
CR1	OPCIONAL (ACCESSORY)

Copyright 2026 - PULLTECH
All Rights Reserved

PULLTECH

PULLTECH - Engenharia e Indústria de Equipamentos Hidráulicos e Mecânicos LTDA
Rua João Pinto de Faria, S/N - Loteamento São João
Nova Friburgo / RJ - Brasil
CEP: 28605-260
Telefone (Phone): (22) 2522-0155 / E-mail: comercial@pulltech-eng.com
Celular (Mobile): (22) 9.8812-4850
www.pulltech-eng.com



CAT-GT60
REV 2
MAR 2026



Visite (Visit):
www.pulltech-eng.com

PULLTECH[®]

PULLTECH - Engenharia e Indústria de Equipamentos Hidráulicos e Mecânicos Ltda.
Rua João Pinto de Faria, S/N - Loteamento São João
Nova Friburgo / RJ - Brasil
CEP: 28605-260

Telefone (Phone): (22) 2522-0155 / E-mail: comercial@pulltech-eng.com
Celular (Mobile): (22) 9.8812-4850
www.pulltech-eng.com