



PULLTECH[®]

GPL2050

**30.00 KGF
(6,600 LBF)**

GUINCHO PNEUMÁTICO DE LEVANTAMENTO PNEUMATIC HOIST WINCH

CARACTERÍSTICAS FEATURES

- Freio multi-discos, normalmente aplicado por molas, liberado por pressão pneumática. Confere ao guincho a capacidade de frear a carga mesmo ocorrendo falha pneumática. Freio em conjunto com embreagem uni-direcional anti-recuo.
- Redutor planetário altamente compacto, montado internamente ao tambor, composto por engrenagens em aço ligado, tratadas termicamente, conferindo elevada vida útil ao equipamento.
- Acionado por motor pneumático de pistões radiais, de alto rendimento e design robusto, com comandos local ou remoto.
- Tambor montado sob rolamentos de alto desempenho, maximizando a eficiência.
- Peso Bruto (Sem Cabo de Aço): 218 Kgf.
- Multi-disc brake, normally applied by spring, pneumatically released. Gives to the winch brake capacity even under pneumatic failure. Brake mounted with one-direction overriding clutch.
- Compact planetary gear reducer, mounted inside the drum, compound by alloy steel gears, heat treated, giving to the equipment a higher life cycle.
- Driven by radial piston air motor, rugged design, with local or remote controls.
- Drum mounted over high performance anti-friction bearings used to maximize efficiency.
- Gross Weight (W/O Wire Rope): 481 LB

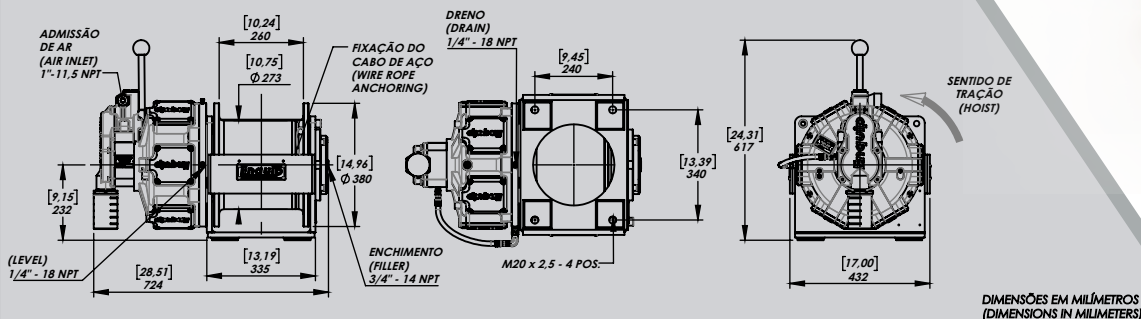

Copyright 2026 - PULLTECH
All Rights Reserved



DESEMPENHO POR CAMADA PERFORMANCE BY LAYER

GPL2050-A-38/MP14

1.387,3 cc Motor Pneumát. (Pneumatic Motor) (84.7 ci)
7 bar (102 PSI) @ 10 m³/min (353 ft³/min)
Diâm. Cabo (Wire Rope Diameter): 13 mm (1/2")

	TRAÇÃO LINE PULL		VEL. LINHA LINE SPEED	
	KGF	LBF	M/MIN.	FT/MIN.
1	1.605	3,538	23,3	76.4
2	1.471	3,243	25,5	83.7
3	1.358	2,994	27,6	90.6
4	1.261	2,780	29,7	97.4

GPL2050-A-49/MP14

1.387,3 cc Motor Pneumát. (Pneumatic Motor) (84.7 ci)
4,5 bar (65 PSI) @ 20 m³/min (706 ft³/min)
Diâm. Cabo (Wire Rope Diameter): 13 mm (1/2")

	TRAÇÃO LINE PULL		VEL. LINHA LINE SPEED	
	KGF	LBF	M/MIN.	FT/MIN.
1	2.963	6,532	7,0	23.0
2	2.716	5,988	7,6	24.9
3	2.507	5,527	8,2	26.9

GPL2050-A-73/MP14

1.387,3 cc Motor Pneumát. (Pneumatic Motor) (84.7 ci)
7 bar (102 PSI) @ 10 m³/min (353 ft³/min)
Diâm. Cabo (Wire Rope Diameter): 13 mm (1/2")

	TRAÇÃO LINE PULL		VEL. LINHA LINE SPEED	
	KGF	LBF	M/MIN.	FT/MIN.
1	2.407	5,307	12,2	40.0
2	2.206	4,863	13,3	43.6
3	2.037	4,491	14,4	47.2

OPCIONAIS OPTIONS:

- Kit Lubrifil (Conj. de Tratamento de Ar) para a linha de admissão de ar comprimido
- Diferentes combinações de redução
- Tambor ranhurado
- Prensa-cabo montado sobre o tambor, auxiliando a organização do cabo durante bobinamento ou desbobinamento
- Comando local ou remoto
- Grade de proteção sobre tambor

- Air treatment kits for air inlet port
- Different gear ratios
- Grooved drum
- Tension roller kit mounted over the drum, helping to organize the wire rope during winding or unwinding
- Local or remote control
- Drum guard

ARMAZENAMENTO STORAGE CAPACITY:

CABO (ROPE) Ø: 9,5-16 mm

TAMBORES DRUMS	A
CAMADAS LAYERS	4~2
QUANTIDADE LENGTH	28~96m (92~315ft)

CÓDIGO (CODE EXPLANATION):

GPL 2050 - A - 38 / MP14

GPL	GUINCHO PNE. DE LEVANTAM. (PNEUMATIC HOIST WINCH)
2050	SÉRIE (SERIE)
A	MODELO TAMBOR (DRUM MODEL)
38	REDUÇÃO TOTAL (OVERALL GEAR RATIO)
MP14	MODELO MOTOR (MOTOR MODEL)

Copyright 2026 - PULLTECH
All Rights Reserved





Visite (Visit):
www.pulltech-eng.com

PULLTECH[®]

PULLTECH - Engenharia e Indústria de Equipamentos Hidráulicos e Mecânicos Ltda.
Rua João Pinto de Faria, S/N - Loteamento São João
Nova Friburgo / RJ - Brasil
CEP: 28605-260

Telefone (Phone): (22) 2522-0155 / E-mail: comercial@pulltech-eng.com
Celular (Mobile): (22) 9.8812-4850
www.pulltech-eng.com